

COM Express Basic Type 6 module with socket G2 supports Intel® 2nd & 3rd generation Core™ i7/i5/i3 Celeron® processor, VGA/LVDS, DDI, GbE, SATA 6Gb/s, USB 3.0, Audio and RoHS

ICE-QM770

Quick Installation Guide

Version 1.00

Oct, 1, 2012

Package Contents

ICE-QM770 package includes the following items:

- 1 x ICE-QM770-R10 single board computer
- 1 x Heat Spreader
- 1 x Cooler
- 1 x Driver CD
- 1 x Utility CD
- 1 x QIG (Quick Installation Guide)

WARNING!

Never run the embedded module without the heat sink. The heatspreader plate shipped with the ICE-QM770 acts as a thermal interface between the module and the heat sink. The heat sink must be installed on the heatspreader plate to maintain proper operating temperatures. Make sure to maintain the heatspreader plate temperature under 60°C in operation.



©2006 Copyright by IEI Technology corp.
All rights reserved.

Specifications

- Form Factor
PICMG COM Express R2.0 Basic Type 6
- CPU
Socket G2 supports Intel® 2nd & 3rd generation Core™
i7/i5/i3/Celeron® processor
- PCH
Intel® QM77
- Memory
Two 204-pin 1600/1333/1066 MHz dual-channel DDR3 SDRAM
unbuffered DIMMs supported (system max. 16GB)
Supports 1.35V DDR3L
- BIOS
UEFI BIOS
- Graphics Engine
Intel® HD Graphics 2000/3000
Supports DX11, OCL 1.1 and OpenGL 3.0
Full MPEG2, VC1, AVC Decode
- Display Output
VGA integrated in the Intel® QM77 (signal to baseboard)
3 x DDI (up to 2560 x 1600 @60Hz)
1 x VGA up to QXGA (up to 2048 x 1536 @75Hz)
1 x 18/24-bit dual-channel LVDS (up to 1920 x 1200 @60Hz)
- Ethernet
Intel® 82579LM
- Embedded Controller
iWDD
- I/O Interface
2 x RS-232 (to baseboard) 8 x USB 2.0 (to baseboard)
4 x USB 3.0 (to baseboard) 2 x SATA 3GB/s (signal to baseboard)
2 x SATA 6Gb/s (signal to baseboard)
- Audio
High definition audio interface

- SMBus
Yes (to baseboard)
- I2C
Yes (to baseboard)
- LPC
Yes (to baseboard)
- Expansions
1 x PCIe x16 signal (to baseboard)
7 x PCIe x1 signal (to baseboard)
- Watchdog Timer
Software programmable supports 1~255 sec. system reset
- GPIO
8-bit GPIO (to baseboard)
- TPM
Through the baseboard
- Intel® AMT
Supports Intel® AMT 8.0
- Power Consumption
+12V@1.75A, Vcore _12V@3.33A
- Operating Temperature
-10°C ~ 60°C
- Operating Humidity
5% ~ 95%, non-condensing
- Dimensions
125 mm x 95 mm
- Weight
GW: 700g/NW: 250g

Ordering Information

ICE-GM45A-R11: COM Express Basic Type 6 module, Intel® 22nm Core™ i7/i5/i3 processor, VGA/LVDS, GbE, SATA 6Gb/s, USB 3.0, Audio and RoHS
ICE-DB-T6-R10: Base Board for COM Express Type 6 modules

Table of Jumper Setting

LABEL	FUNCTION
SW1	LCD Panel Type Setting switch

1. LVDS Panel type Selection

The Panel type of LVDS can be selected by using SW1. ON=0 OFF=1

SW1 4321	EDID Resolution	Color Depth	Channel
0000	640X480	18-bit	Single
0001	800X480	18-bit	Single
0010	800X600	18-bit	Single
0011	1024X768	18-bit	Single
0100	1024X768	24-bit	Single
0101	1280X1024	24-bit	Dual
0110	1600X1200	24-bit	Dual
0111	1280X768	18-bit	Single
1000	1280X800	18-bit	Single
1001	1366X768	24-bit	Single
1010	1440X900	24-bit	Dual
1011	1600X900	24-bit	Dual
1100	1680X1050	24-bit	Dual
1101	1920X1080	24-bit	Dual
1110	1920X1200	24-bit	Dual
1111	LVDS disable		

Table of Connectors

LABEL	FUNCTION
JSPI1	FLASH SPI ROM (BIOS)
JSPI2	FLASH SPI ROM (EC)
J3	COM Express Connector AB
J4	COM Express Connector CD

1. Flash SPI ROM (BIOS)

• JSPI1: Flash BIOS SPI ROM

PIN NO.	DESCRIPTION
1	+V3.3M_SPI_CON
2	SPI_CS
3	SPI_SO_SW
4	SPI_CLK_SW
5	SPI_SI_SW
6	GND

2. Flash SPI ROM (EC)

• JSPI2: Flash BIOS SPI ROM

PIN NO.	DESCRIPTION
1	+V3.3M_SPI_CON_EC
2	SPI_CS#0_CN_EC
3	SPI_SO_SW_EC
4	SPI_CLK_SW_EC
5	SPI_SI_SW_EC
6	GND

3. COM Express Connector AB

- J3: The standard COM Express connector AB location and pinouts are shown below

Pin No.	Description	Pin No.	Description
A1	GND	B1	GND15
A2	GBE0_MDI3-	B2	GBE0_ACT#
A3	GBE0_MDI3+	B3	LPC_FRAME#
A4	GBE0_LINK100#	B4	LPC_AD0
A5	GBE0_LINK1000#	B5	LPC_AD1
A6	GBE0_MDI2-	B6	LPC_AD2
A7	GBE0_MDI2+	B7	LPC_AD3
A8	GBE0_LINK#	B8	LPC_DRQ0#
A9	GBE0_MDI1-	B9	LPC_DRQ1#
A10	GBE0_MDI1+	B10	LPC_CLK
A11	GND1	B11	GND16
A12	GBE0_MDI0-	B12	PWRBTN#
A13	GBE0_MDI0+	B13	SMB_CK
A14	GBE0_CTREF	B14	SMB_DAT
A15	SUS_S3#	B15	SMB_ALERT#
A16	SATA0_TX+	B16	SATA1_TX+
A17	SATA0_TX-	B17	SATA1_TX-
A18	SUS_S4#	B18	SUS_STAT#
A19	SATA0_RX+	B19	SATA1_RX+
A20	SATA0_RX-	B20	SATA1_RX-
A21	GND2	B21	GND17
A22	SATA2_TX+	B22	SATA3_TX+
A23	SATA2_TX-	B23	SATA3_TX-
A24	SUS_S5#	B24	PWR_OK
A25	SATA2_RX+	B25	SATA3_RX+
A26	SATA2_RX-	B26	SATA3_RX-
A27	BATLOW#	B27	WDT
A28	ATA_ACT#	B28	AC/HD_SDIN2
A29	AC/HD_SYNC	B29	AC/HD_SDIN1
A30	AC/HD_RST#	B30	AC/HD_SDIN0
A31	GND3	B31	GND18
A32	AC/HD_BITCLK	B32	SPKR
A33	AC/HD_SDOUT	B33	I2C_CK
A34	BIOS_DISABLE#	B34	I2C_DAT
A35	THRMTRIP#	B35	THRM#

Pin No.	Description	Pin No.	Description
A36	USB6-	B36	USB7-
A37	USB6+	B37	USB7+
A38	USB_6_7_OC#	B38	USB_4_5_OC#
A39	USB4-	B39	USB5-
A40	USB4+	B40	USB5+
A41	GND4	B41	GND
A42	USB2-	B42	USB3-
A43	USB2+	B43	USB3+
A44	USB_2_3_OC#	B44	USB_0_1_OC#
A45	USB0-	B45	USB1-
A46	USB0+	B46	USB1+
A47	VCC_RTC	B47	EXCD1_PERST#
A48	EXCD0_PERST#	B48	EXCD1_CPPE#
A49	EXCD0_CPPE#	B49	SYS_RESET#
A50	LPC_SERIRQ	B50	CB_RESET#
A51	GND5	B51	GND20
A52	PCIE_TX5+	B52	PCIE_RX5+
A53	PCIE_TX5-	B53	PCIE_RX5-
A54	GPI0	B54	GPO1
A55	PCIE_TX4+	B55	PCIE_RX4+
A56	PCIE_TX4-	B56	PCIE_RX4-
A57	GND6	B57	GPO2
A58	PCIE_TX3+	B58	PCIE_RX3+
A59	PCIE_TX3-	B59	PCIE_RX3-
A60	GND7	B60	GND
A61	PCIE_TX2+	B61	PCIE_RX2+
A62	PCIE_TX2-	B62	PCIE_RX2-
A63	GPI1	B63	GPO3
A64	PCIE_TX1+	B64	PCIE_RX1+
A65	PCIE_TX1-	B65	PCIE_RX1-
A66	GND8	B66	WAKE0#
A67	GPI2	B67	WAKE1#
A68	PCIE_TX0+	B68	PCIE_RX0+
A69	PCIE_TX0-	B69	PCIE_RX0-
A70	GND9	B70	GND22
A71	LVDS_A0+	B71	LVDS_B0+
A72	LVDS_A0-	B72	LVDS_B0-
A73	LVDS_A1+	B73	LVDS_B1+
A74	LVDS_A1-	B74	LVDS_B1-

Pin No.	Description	Pin No.	Description
A75	LVDS_A2+	B75	LVDS_B2+
A76	LVDS_A2-	B76	LVDS_B2-
A77	LVDS_VDD_EN	B77	LVDS_B3+
A78	LVDS_A3+	B78	LVDS_B3-
A79	LVDS_A3-	B79	LVDS_BKLT_EN
A80	GND10	B80	GND23
A81	LVDS_A_CK+	B81	LVDS_B_CK+
A82	LVDS_A_CK-	B82	LVDS_B_CK-
A83	LVDS_I2C_CK	B83	LVDS_BKLT_CTRL
A84	LVDS_I2C_DAT	B84	VCC5SBY1
A85	GPI3	B85	VCC5SBY2
A86	RSVD	B86	VCC5SBY3
A87	RSVD	B87	VCC5SBY4
A88	PCIE0_CK_REF+	B88	BIOS_DIS1#
A89	PCIE0_CK_REF-	B89	VGA_RED
A90	GND11	B90	GND24
A91	SPI_VCC	B91	VGA_GRN
A92	SPI_MISO	B92	VGA_BLU
A93	GPO0	B93	VGA_HSYNC
A94	SPI_CLK	B94	VGA_VSYNC
A95	SPI_MOSI	B95	VGA_I2C_CK
A96	PP_TPM	B96	VGA_I2C_DAT
A97	RSVD	B97	SPI_CS#
A98	RS1_TX	B98	RSVD
A99	RS1_RX	B99	RSVD
A100	GND13	B100	GND25
A101	RS2_TX	B101	FAN_PWMOUT
A102	RS2_RX	B102	FAN_TACHIN
A103	LID#	B103	SLEEP#
A104	VCC_12V7	B104	VCC_12V16
A105	VCC_12V8	B105	VCC_12V17
A106	VCC_12V9	B106	VCC_12V18
A107	VCC_12V10	B107	VCC_12V19
A108	VCC_12V11	B108	VCC_12V20
A109	VCC_12V12	B109	VCC_12V21
A110	GND14	B110	GND26

4. COM Express Connector CD

- J4: The standard COM Express connector AB location and pinouts are shown below

Pin No.	Description	Pin No.	Description
C1	GND0	D1	GND15
C2	GND	D2	GND
C3	USB_SSRX0-	D3	USB_SSTX0-
C4	USB_SSRX0+	D4	USB_SSTX0+
C5	GND	D5	GND
C6	USB_SSRX1-	D6	USB_SSTX1-
C7	USB_SSRX1+	D7	USB_SSTX1+
C8	GND	D8	GND
C9	USB_SSRX2-	D9	USB_SSTX2-
C10	USB_SSRX2+	D10	USB_SSTX2+
C11	GND1	D11	GND16
C12	USB_SSRX3-	D12	USB_SSTX3-
C13	USB_SSRX3+	D13	USB_SSTX3+
C14	GND	D14	GND
C15	DDI1_PAIR6+	D15	DDI1_AUX+
C16	DDI1_PAIR6-	D16	DDI1_AUX-
C17	RSVD	D17	RSVD
C18	RSVD	D18	RSVD
C19	PCIE_RX6+	D19	PCIE_TX6+
C20	PCIE_RX6-	D20	PCIE_TX6-
C21	GND2	D21	GND17
C22	RSVD	D22	RSVD
C23	RSVD	D23	RSVD
C24	DDI1_HPD	D24	RSVD
C25	DDI1_PAIR4+	D25	RSVD
C26	DDI1_PAIR4-	D26	DDI1_PAIR0+
C27	RSVD	D27	DDI1_PAIR0-
C28	RSVD	D28	RSVD
C29	DDI1_PAIR5+	D29	DDI1_PAIR1+
C30	DDI1_PAIR5-	D30	DDI1_PAIR1-
C31	GND3	D31	GND18
C32	DDI2_AUX+	D32	DDI1_PAIR2+
C33	DDI2_AUX-	D33	DDI1_PAIR2-
C34	DDI2_CTRLCLK	D34	DDI2_CTRLDATA
C35	RSVD	D35	RSVD

Pin No.	Description	Pin No.	Description
C36	DDI3_AUX+	D36	DDI1_PAIR3+
C37	DDI3_AUX-	D37	DDI1_PAIR3-
C38	DDI3_CTRLCLK	D38	DDI3_CTRLDATA
C39	DDI3_PAIR0+	D39	DDI2_PAIR0+
C40	DDI3_PAIR0-	D40	DDI2_PAIR0-
C41	GND4	D41	GND19
C42	DDI3_PAIR1+	D42	DDI2_PAIR1+
C43	DDI3_PAIR1-	D43	DDI2_PAIR1-
C44	DDI3_HPD	D44	DDI2_HPD
C45	RSVD	D45	RSVD
C46	DDI3_PAIR2+	D46	DDI2_PAIR2+
C47	DDI3_PAIR2-	D47	DDI2_PAIR2-
C48	RSVD	D48	RSVD
C49	DDI3_PAIR3+	D49	DDI2_PAIR3+
C50	DDI3_PAIR3-	D50	DDI2_PAIR3-
C51	GND5	D51	GND20
C52	PEG_RX0+	D52	PEG_TX0+
C53	PEG_RX0-	D53	PEG_TX0-
C54	RSVD	D54	PEG_LANE_RV#
C55	PEG_RX1+	D55	PEG_TX1+
C56	PEG_RX1-	D56	PEG_TX1-
C57	RSVD	D57	TYPE2#
C58	PEG_RX2+	D58	PEG_TX2+
C59	PEG_RX2-	D59	PEG_TX2-
C60	GND7	D60	GND21
C61	PEG_RX3+	D61	PEG_TX3+
C62	PEG_RX3-	D62	PEG_TX3-
C63	RSVD1	D63	RSVD10
C64	RSVD2	D64	RSVD9
C65	PEG_RX4+	D65	PEG_TX4+
C66	PEG_RX4-	D66	PEG_TX4-
C67	RSVD3	D67	GND28
C68	PEG_RX5+	D68	PEG_TX5+
C69	PEG_RX5-	D69	PEG_TX5-
C70	GND9	D70	GND22
C71	PEG_RX6+	D71	PEG_TX6+
C72	PEG_RX6-	D72	PEG_TX6-
C73	DDI1_CTRLDATA	D73	DDI1_CTRLCLK
C74	PEG_RX7+	D74	PEG_TX7+

Pin No.	Description	Pin No.	Description
C75	PEG_RX7-	D75	PEG_TX7-
C76	GND8	D76	GND29
C77	RSVD4	D77	RSVD
C78	PEG_RX8+	D78	PEG_TX8+
C79	PEG_RX8-	D79	PEG_TX8-
C80	GND10	D80	GND23
C81	PEG_RX9+	D81	PEG_TX9+
C82	PEG_RX9-	D82	PEG_TX9-
C83	RSVD5	D83	RSVD8
C84	GND6	D84	GND30
C85	PEG_RX10+	D85	PEG_TX10+
C86	PEG_RX10-	D86	PEG_TX10-
C87	GND35	D87	GND31
C88	PEG_RX11+	D88	PEG_TX11+
C89	PEG_RX11-	D89	PEG_TX11-
C90	GND27	D90	GND24
C91	PEG_RX12+	D91	PEG_TX12+
C92	PEG_RX12-	D92	PEG_TX12-
C93	GND11	D93	GND32
C94	PEG_RX13+	D94	PEG_TX13+
C95	PEG_RX13-	D95	PEG_TX13-
C96	GND12	D96	GND33
C97	RSVD6	D97	PEG_ENABLE#
C98	PEG_RX14+	D98	PEG_TX14+
C99	PEG_RX14-	D99	PEG_TX14-
C100	GND13	D100	GND25
C101	PEG_RX15+	D101	PEG_TX15+
C102	PEG_RX15-	D102	PEG_TX15-
C103	GND	D103	GND34
C104	VCC_12V1	D104	VCC_12V7
C105	VCC_12V2	D105	VCC_12V8
C106	VCC_12V3	D106	VCC_12V9
C107	VCC_12V4	D107	VCC_12V10
C108	VCC_12V5	D108	VCC_12V11
C109	VCC_12V6	D109	VCC_12V12
C110	GND14	D110	GND26

Board Layout: Jumper and Connector Locations

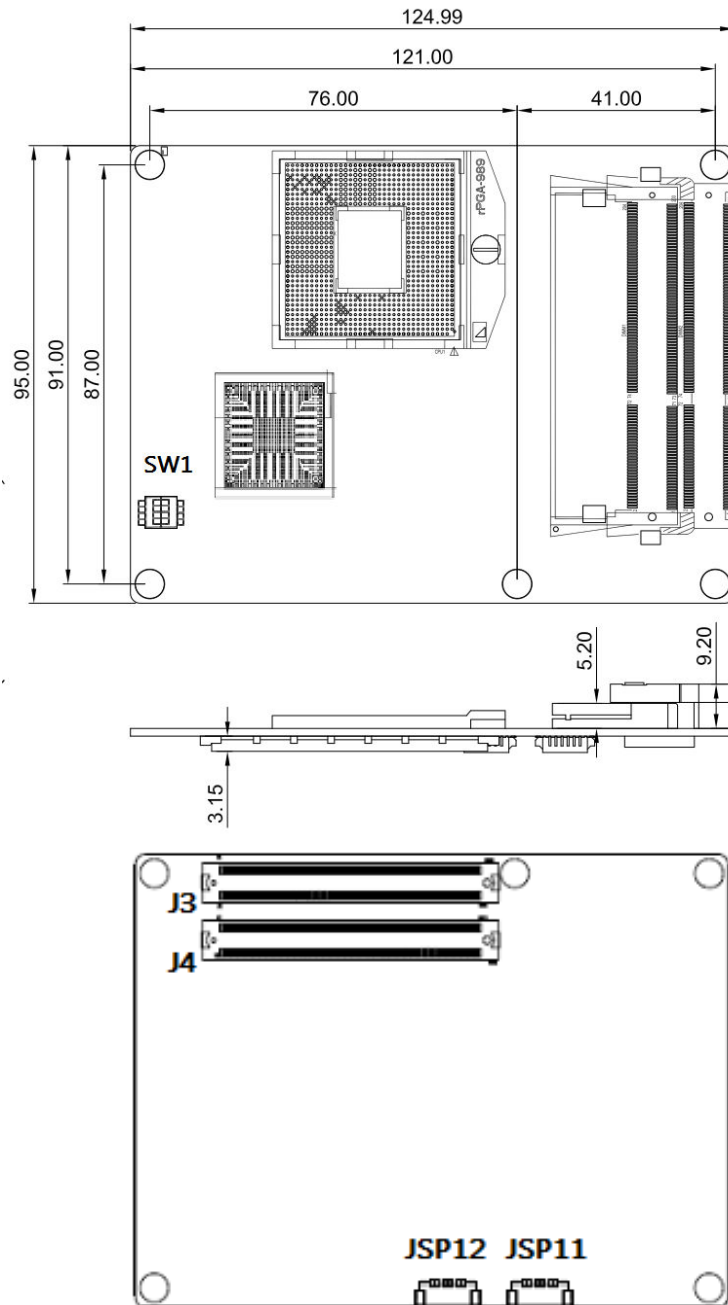

Board with Heat Spreader and Cooler dimensions:

